

"RP20 RG" EXTRA

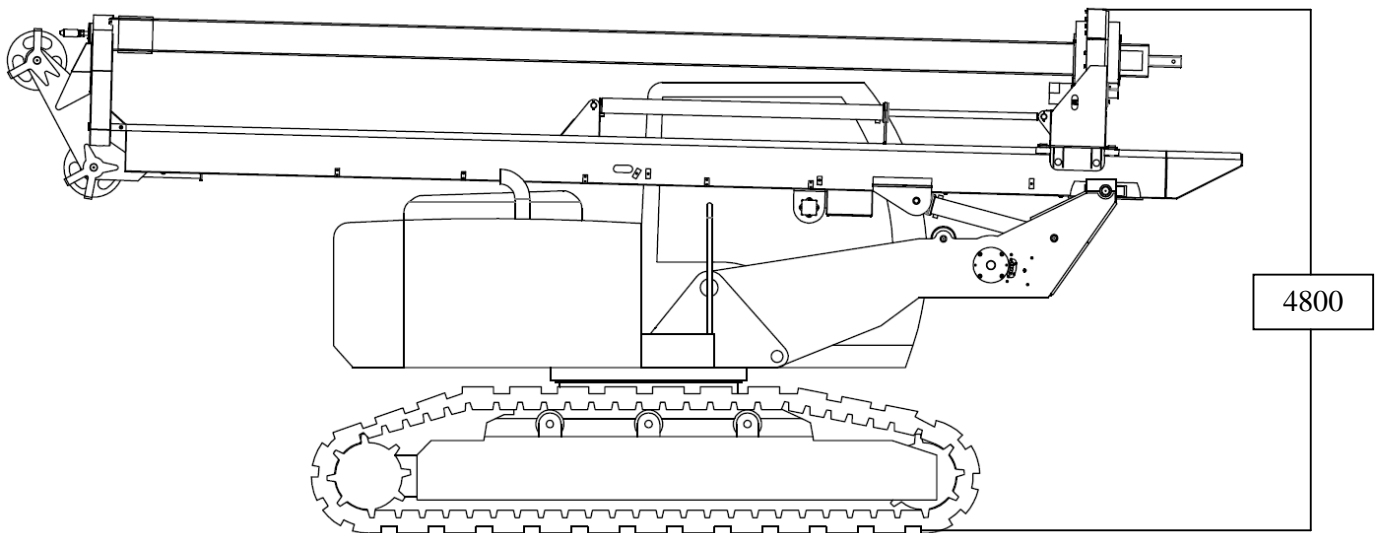

"RP20 RG" EXTRA

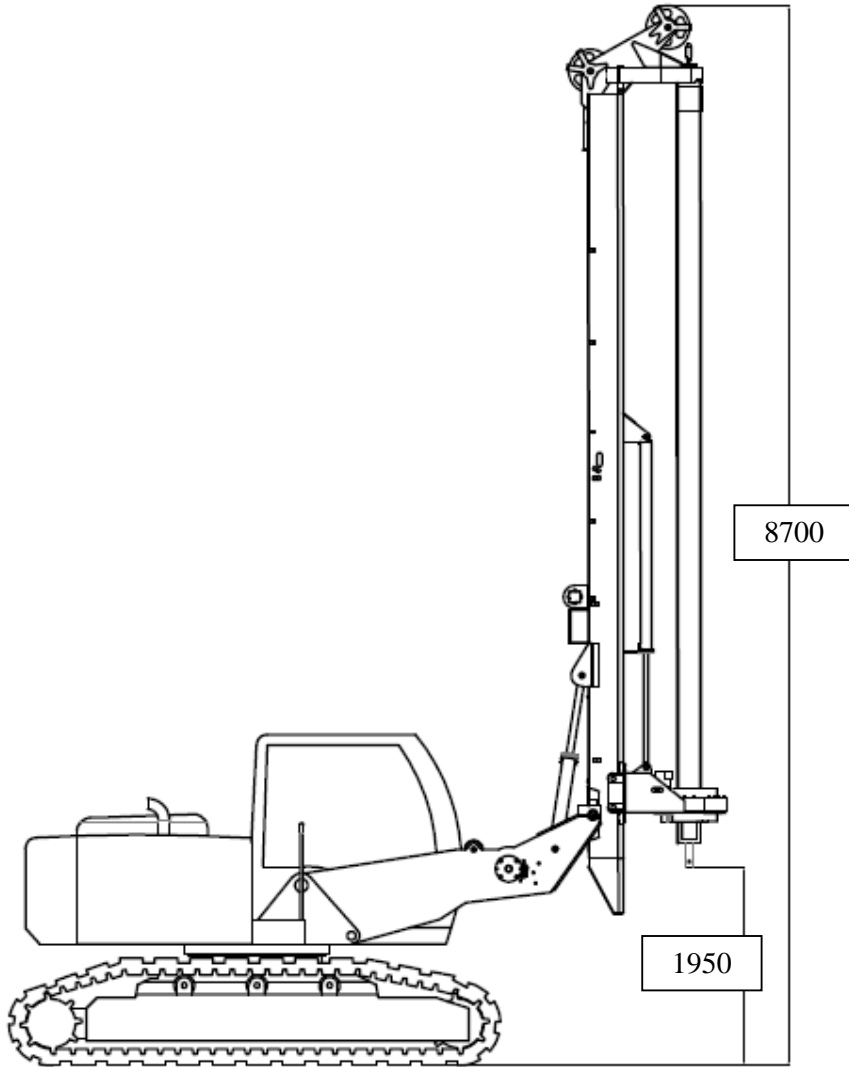

ESPECIFICACIONES TECNICAS:

Datos:

**Modelo "RP 20
RG" EXTRA**

CABEZAL:

Torque HTA.	(Kgm)	3500
Velocidad de trabajo.	RPM	15
Velocidad de limpieza.	RPM	50

CABRESTANTES:

Fuerza de tiro.	(Kg)	4500
Diámetro cable.	(mm)	16
Fuerza tiro cabrestante aux.	(Kg)	1000
Diámetro cable (aux).	(mm)	8

POOL DOOWN:

Empuje de Kelly.	(Kg)	5000
Tiro de Kelly.	(Kg)	3500
Recorrido de cabezal.	(mm)	2000

KELLY

Tramos/Profundidad.	04/20mts.
Diámetro máximo perforación.	(mm) 1000
Peso total del Equipo.	(Kg) 7000

Nota: todos los datos técnicos son indicativos. "RenMaa S.A.S" se reserva la facultad de modificarlos oportunamente.